

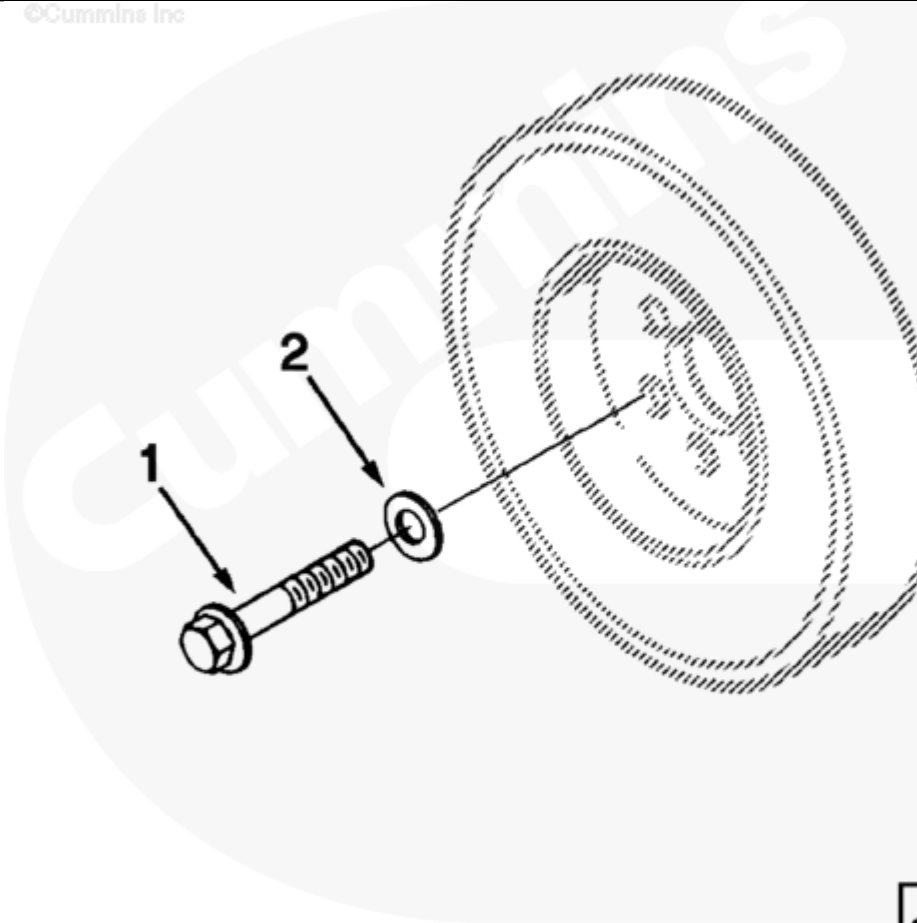

Parts Catalog - Option Detail

Electronic Parts Catalog - Option Detail				
Option	Group	Graphic	Film Card	Date
DA1703	01.02.2	em100gk	F	12-NOV-90
Engines	NH/NT 855, NT495, NT743, NTA855 N106			

©Cummins Inc



em100gk

[SMALL](#) | [MEDIUM](#) | [LARGE](#)

Cart	Ref No	Part Number	Part Description	Required	Remarks
View My Cart					
		DA1703	Vibration Damper		
					Vibration Damper
					Damper to crankshaft mounting
					with six 2 1/4 inch 12 point

					capscrews. Usually
					Used with single or two
					groove crank pulley combined
					with and adapter for
					Front PTO from crankshaft and
					pad type front engine
					mounting.
<input type="checkbox"/>	1	212113	Twelve Point Cap Screw	6	5/8 - 18 x 2 1/4 inch
<input type="checkbox"/>	2	127316	Plain Washer	6	5/8 in.

© 2019 Cummins Inc., Box 3005, Columbus, IN 47202-3005 U.S.A.
Terms of Use and Disclaimers | Recommended System Requirements
Need Assistance? Please click on the Contact Us button in the top right corner of any page.